

DT621

Tunneling drill

Key features

Coverage area	49 m ² (8 820 x 6 060 mm)
Hydraulic rock drill	2 x RD520 (20 kW)
Drill feed	2 x TF500-12' (12' to 16')
Boom	2 x SB40
Control system	THC561, hydraulic
Hole length	Up to 4 660 mm
Turning width (T-section)	3 500 mm (with TF500-16')
Transport / drilling width	2 150 mm
Transport / drilling height	2 350 mm / 3 200 mm
Transport length	12 350 mm (with TF500-12')
Total weight depending on options	22 000 kg

Sandvik DT621 is a compact two-boom jumbo for demanding conditions and multiple applications.

The jumbo is capable of face drilling, cross-cut drilling and bolt hole drilling.

The drill rig various options make it suitable for a range of conditions and tasks. The proven and robust SB40 boom provides coverage of 49 m².

A selection of fixed and telescopic feeds are available for a variety of applications.

The new rock drill RD520 provides smooth and efficient drilling.

Sandvik DT621 offers a best serviceability and usability.



Technical Specification

Hydraulic rock drill

Type of rock drill	RD520 (TS2-235)
Percussion power	20 kW
Percussion pressure	Max. 220 bar
Percussion rate	74 Hz
Stabilizer	Hydraulic
Rotation speed	Max. 400 rpm (with OMS80)
Rotation torque	400 Nm (with OMS80)
Hole size (drifting)	43 - 64 mm
Hole size (cut hole)	76 - 127 mm
Recommended tools 43 - 45 mm:	T38 - H35 - Alpha 340
48 - 51 mm:	T38 - H35 - Alpha 360
	T38 - R39 - Alpha 360
Shank adapter	T38 (male)
Weight	225 kg
Length	1 010 mm
Profile height	90 mm

Feed

Type of feed	TF500-12' Standard	TF500-14' Optional	TF500-16' Optional
Feed force (Max.)	25 kW	25 kW	25 kW
Total length	5 270 mm	5 880 mm	6 490 mm
Hole length	3 440 mm	4 050 mm	4 660 mm
Rod length	3 700 mm	4 305 mm	4 915 mm
Net weight	500 kg	530 kg	560 kg

Boom

Type of boom	SB40 (TS2-231)
Parallel coverage	44.5 m ²
Parallelism	Automatic hydraulic
Boom extension	1 050 mm
Feed extension	1 350 mm
Boom weight, net	2 100 kg
Roll-over angle	358 °

Hydraulic system

Powerpack	HPP555 (2 x 55 kW)
Filtration size (pressure / return)	20 µ / 10 µ
Oil tank volume	270 liters (drilling)
Filling pump for hydraulic oil	Electric
Cooler for hydraulic oil	OW30 oil-to-water (2 x 30 kW)

Control system

Type of control system	THC561, hydraulic (TS2-362)
Manual boom control	Direct control Fully proportional Hydraulic parallelism
Drilling control	Feed / percussion control Flushing control
Automatic cycle	Stop and return automatics

Electric system

Standard voltage	380 - 690 V (± 10%), 50 Hz
Total input power	135 kW
Main switch	MSE20
IP classification	Specification TS2-132
Starting method	Star-delta starter 380 - 690 V
Automatic cable reel	TCR3E with spooling system
Cable reel control (in / out)	Operator station and remote control at rear machine
Batteries	2 x 12 V, 145 Ah
Front lights (combined working and driving)	6 x 50 W LED (24V)
Rear lights (combined working and driving)	4 x 50 W LED (24 V)
Rear parking / brake lights	2 x Red LED (24V)
Stair and service lights	LED (24V)

Air and water system

Flushing of holes	By water
Water booster pump type	WBP2
Water pump capacity	100 l/min
Water pump inlet pressure	2 bar (mini)
Flushing water pressure	10 - 15 bar
Shank lubrication device	SLU-2 (air / oil mist)
Air compressor	CTN10 (1.0 m ³ /min at 7 bar)
Oil consumption	180 - 250 g/h
Air consumption	250 - 350 l/min

Operator's safety canopy

Canopy certification	FOPS (ISO 3449)
Unit height in tramming	3 200 mm
Sound pressure level according to EN 16228	Cabin < 103 dB(A) Emitted 126 dB(A)
Operation	Standing drilling, seated tramming
Operator's seat	For tramming Adjustable with seat belt

Technical Specification

Carrier

Type of carrier	NC7 (frame-steered)
Carrier articulation	± 40°
Rear axle oscillation	± 10°
Ground clearance	320 mm
Diesel engine	Cummins QSB 4.5, 124 kW, Stage IIIA
Exhaust catalyzer	Standard
Transmission	Hydrodynamic, Spicer T20 000
Axles	Spicer
Tires	12.00-20
Service brakes	SAHR type, fail safe wet disc brakes
Parking / emergency brakes	SAHR type, fail safe wet disc brakes
Fuel tank	140 liters
Tramming speed	Horizontal (0°): 16 km/h 14% = 1:7 = 8°: 6 km/h
Gradeability / sideways tilt	Max. 15°/5° (according to EN 16228-2)
Carrier stabilization	2 x Vertical (front) 2 x Vertical (rear)
Rod rack on carrier side	For 10 - 16 ft rods and two shank adapters
Hand held fire extinguisher	1 x 7.7 or 9 kg (type ABC)
Carrier centralized greasing	Specification TS2-463
Tramming alarm	Standard
Knowledge Box™	Connectivity solution (TS2-535)
Colour scheme	Sandvik standard
Documentation	1 x Operator's manual 1 x Maintenance manual 1 x Technical manual (in English only) 1 x Parts manual (in English only) 2 x Toolman USB key

Optional items

Rock drill	
*Type of rock drill	RDX5 (OMS80) instead of RD520
Feed	
*Feed length	14', 16'
*Telescopic feed	TFX6/12, TFX8/14
Rod retainer	TRR1 with TFX feed (incl. safety wire)
Two rods system	TRS included TRR1 with safety wire.
Boom	
*Type of boom	SB40NV instead of SB40
Hydraulic system	
*Filling pump for hydraulic oil	Manual
Cooler for hydraulic oil	OA30 oil-to-air (2x30 kW)
Vaccum pump	For hydraulic system
Control system	
Constant speed drilling	Replaces feed / percussion control
Access detector system	Mandatory in Europe (TS2-211)
Instrumentation	TMS+D2 for TF and TFX feeds TMS+DDSS2 for TF feeds only TCAD+ iSURE® software (incl. basic license for one year)
Cleaning system	
Low pressure system with reel	Up to 15 bar (TS2-343)
High pressure system with reel	Up to 180 bar (TS2-343)
Greasing systems	
Manual system	Greasing unit with pump, reel and nozzle (TS2-463)
Automatic system	Lincoln (for carrier and boom)

Optional items

Electric system	
*Optional voltage	1 000 V (50 or 60 Hz) with Direct-On-Line starter Specification TS2-121
*Electric cable	VYK
Ground fault and overcurrent protection	VYK
Electric current draw reducer unit	
Auxiliary outlet	1 x 110 V or 1 x 230 V, 16 A
Battery jump start	Option
Dewatering pump outlet readiness	Site voltage 380 - 690 V (Max. 8 kW)
Amber flashing light	LED (24 V)
Air and water system	
Air mist flushing kit	IP5 air cleaner and flow control
Flushing flow control	2 booms
*End of hole air flushing	Including CT28 air compressor
Water hose reel with water hose	THR2.5E with 38 mm (1 ½"), 65 m
Compressed air outlet	Quick coupling
Operator's safety canopy	
*Safety cabin	FOPS / ROPS (ISO 3449 / 3471) incl. air conditioning
*Stainless steel cabin	FOPS (ISO 3449)
Cabin heating	During tramming and drilling
Cabin audio system	MP3 player with loudspeakers and 12 V outlet
Boot washer	At each access
Front screen protection grill	For cabin or canopy
Fire suppression system	
Spare hand held extinguisher	1 x 7.7 or 9 kg (type ABC)
Manual or automatic system	Ansul, 6 nozzles (TS2-460)
Automatic system	Sandvik Eclipse™ (TS2-461)
Carrier	
Reduced tramming speed	3 rd gear lockout
*Diesel engine	B4.5, 129 kW, Tier 4F, Stage V
*Foam filled tires	4 pcs
Fast filling and evacuation system	Wiggins (complete)
Wheel chocks and holders	2 Sets
Tramming cameras	Rear and side
Rod rack and shank holder	On carrier side
Extra items	
Spare rock drill	RD520 or RDX5
Spare wheel assembly	Standard or foam filled tires
Special tools for rock drill	Field tool set Complete tool set
Warranty extension	One year (excl. Kazakhstan)*
Documentation	Extra manuals
iSURE®	Complete license (for one year)
Package: Country specific options	LAM, USC, EUR, Turkey package
*Package: Harsh water	Basic or advanced (Spec. TS2-049)

*) *Replaces standard feature*

Technical drawings

All dimensions in mm

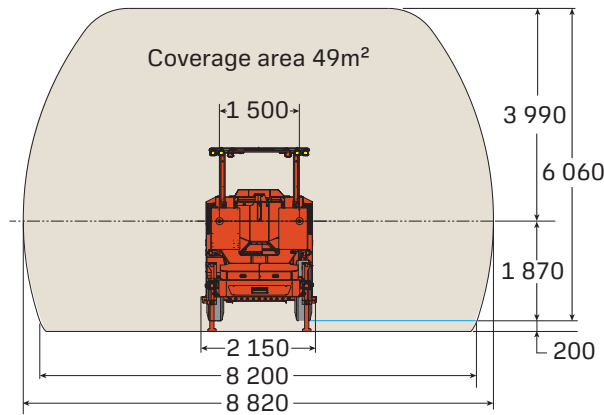

	TF500-12'	TF500-14'	TF500-16'	TFX6/12	TFX8/14
Overall length	12 350 mm	12 550 mm	13 000 mm	11 900 mm	11 900 mm

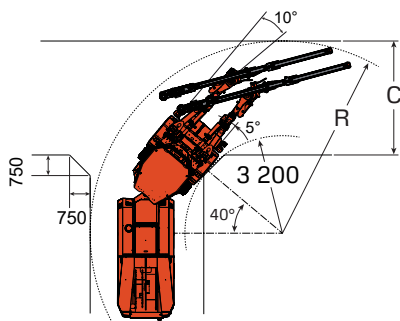
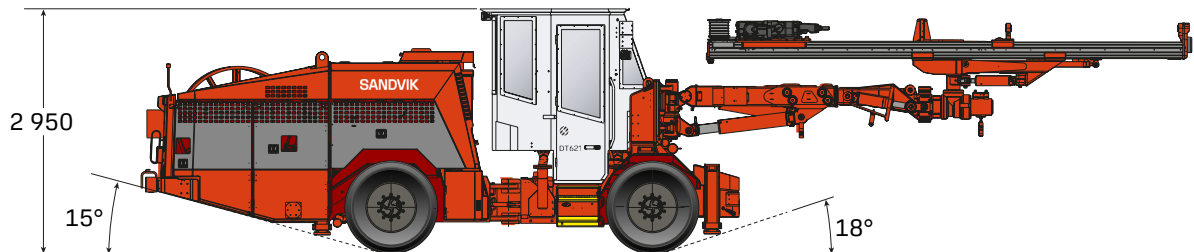
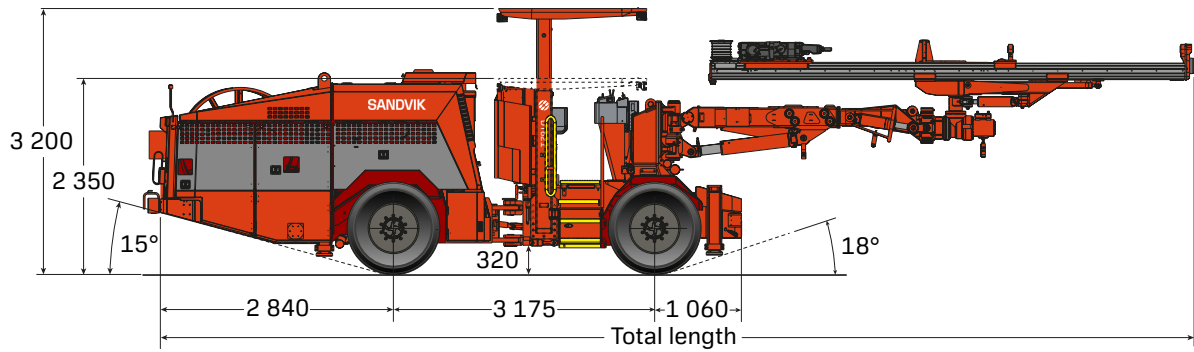

	Radius (R)	T-cross (C)
DT621 (TF500-12')	6 300 mm	3 700 mm
DT621 (TF500-14')	6 450 mm	3 850 mm
DT621 (TF500-16')	6 600 mm	4 000 mm
DT621 (TFX6/12)	6 250 mm	3 600 mm
DT621 (TFX8/14)	6 250 mm	3 600 mm