

Declaration of Performance

No. HBS-2026-001 R51-800

1. Product type:

Self-drilling soil and rock nails

DSI® Hollow Bar System R51-800

2. Intended use/es:

Soil and rock nails are intended to stabilise soil and rock by the installation of passive tensile elements.

3. Manufacturer:

DSI Underground Austria GmbH
Alfred-Wagner-Straße 1, 4061 Pasching / Linz, Austria

4. System of assessment and verification of constancy of performance:

1+

5. European Assessment Document:

EAD 160088-00-0102

6. European Technical Assessment:

ETA-21/0869 of 2.8.2022

7. Technical Assessment Body (TAB):

Austrian Institute of Construction Engineering
Schenkenstrasse 4, 1010 Vienna, Austria

8. Accredited certification body (NB 1379):

Technical University of Graz

9. Declared performance/s:

	Essential characteristic	Intended Use		
		Temporary Soil and Rock Nail	Permanent Soil and Rock Nail	
			Bare Soil and Rock Nail	Hot-dip galvanised Soil and Rock Nail
1	Resistance to static load of anchorages and coupler assemblies	$F_{p0.2, nom}: 640 \text{ kN}$, $F_{m, nom}: 800 \text{ kN}$, Slip at 65 % $F_{p0.2, nom}$ coupling: 0.9 mm, anchorage: 0.3 mm		
2	Resistance to fatigue of anchorages and coupler assemblies	$F_{p0.2, nom}: 640 \text{ kN}$, $2\sigma_a: 80 \text{ N/mm}^2$		
3	Load transfer to structure	$f_{cm, 0}: 38 \text{ N/mm}^2$, $F_{m, nom}: 800 \text{ kN}$		
4	Corrosion protection for temporary rock and soil nails	Cover of cement grout mortar $\geq 15\text{mm}$ Attachment 1, Figure 1	-	
5	Corrosion protection, sacrificial corrosion allowance for permanent rock and soil nails	-	Sacrificial corrosion Attachment 1, Figure 1, Attachment 1, Table 1	-
6	Corrosion protection, sacrificial corrosion allowance for hot-dip galvanised permanent rock and soil nails	-		Sacrificial corrosion Attachment 1, Figure 1, Attachment 1, Table 2
7	Impact energy and torque	$E_S: 190 \text{ Joule}$, $M_t: 2270 \text{ Nm}$ to $E_S: 270 \text{ Joule}$, $M_t: 1700 \text{ Nm}$		
Hollow bar of welded steel tube				
8	Shape	Attachment 1, Figure 2		
9	Dimensions	Diameter External: 49.8 mm, Internal: 29.0 mm		
10	Surface geometry	Rope thread, pitch 12.7 mm, average thread height 1.6 mm, $f_R: 0.13$		
11	Mass per metre	9.00 kg/m, deviation: - 4.5 % to + 12 %		
12	Cross sectional area	1150 mm ²		
13	Strength characteristics	$F_{p0.2, nom}: 640 \text{ kN}$, $F_{m, nom}: 800 \text{ kN}$, $F_m/F_{p0.2}: \geq 1.15$		
14	Elongation at maximum force	$A_{gt} \geq 5 \%$		
15	Modulus of elasticity	205 000 N/mm ²		
16	Weld at flattening	No cracking at close flattening prior to rolling		
17	Weld at drift expansion	No cracking at relative expansion $\geq 110 \%$ with 60 ° mandrel prior to rolling		
18	Resistance to fatigue	$F_{p0.2, nom}: 640 \text{ kN}$, $2\sigma_a: 190 \text{ N/mm}^2$, 2 000 000 cycles		
19	Bond strength	$\tau_{ak}: 5.1 \text{ N/mm}^2$, $f_{cm}: 55 \text{ N/mm}^2$		
20	Hot-dip galvanising	-	-	$\geq 85 \mu\text{m}$

The performance of the product identified above is in conformity with the set of declared performance/s.

Signed for and on behalf of the manufacturer by:

Signed by:

 8B67F3C8A00D446...

Dipl.-Ing. Dominik Johannes Dendl

Pasching, on 08.04.2026

Declaration of Performance

No. HBS-2026-001 R51-800 Attachment 1

Figure 1: Coupler, Nut

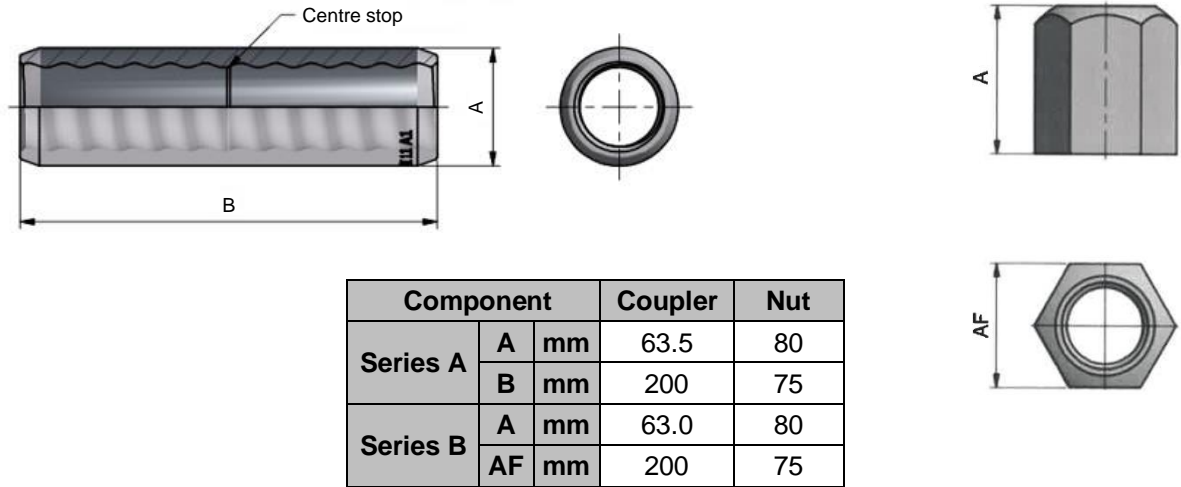

Table 1: Bare steel

Time in years	Corrosion load		
	Low	Medium	High
	Sacrificial corrosion depth in mm		
2	0	0	0.2
7	0.2	0.2	0.5
30	0.3	0.6	-
50	0.5	1.0	-

Table 2: Galvanised steel

Time in years	Corrosion load		
	Low	Medium	High
	Sacrificial corrosion depth in mm		
2	0	0	0.1
7	0	0.1	0.4
30	0.1	0.4	-
50	0.3	0.7	-

Figure 2: Hollow bar

