

## **Declaration of Performance**

No. HBS-2026-001 R32-210

**1. Product type:**

Self-drilling soil and rock nails

DSI® Hollow Bar System R32-210

**2. Intended use/es:**

Soil and rock nails are intended to stabilise soil and rock by the installation of passive tensile elements.

**3. Manufacturer:**

DSI Underground Austria GmbH  
Alfred-Wagner-Straße 1, 4061 Pasching / Linz, Austria

**4. System of assessment and verification of constancy of performance:**

1+

**5. European Assessment Document:**

EAD 160088-00-0102

**6. European Technical Assessment:**

ETA-21/0869 of 2.8.2022

**7. Technical Assessment Body (TAB):**

Austrian Institute of Construction Engineering  
Schenkenstrasse 4, 1010 Vienna, Austria

**8. Accredited certification body (NB 1379):**

Technical University of Graz

**9. Declared performance/s:**

	Essential characteristic	Intended Use		
		Temporary Soil and Rock Nail	Permanent Soil and Rock Nail	
			Bare Soil and Rock Nail	Hot-dip galvanised Soil and Rock Nail
1	Resistance to static load of anchorages and coupler assemblies	$F_{p0.2, nom}$ : 160 kN, $F_{m, nom}$ : 210 kN, Slip at 65 % $F_{p0.2, nom}$ coupling: 0.9 mm, anchorage: 0.3 mm		
2	Resistance to fatigue of anchorages and coupler assemblies	$F_{p0.2, nom}$ : 160 kN, $2\sigma_a$ : 80 N/mm <sup>2</sup>		
3	Load transfer to structure	$f_{cm, 0}$ : 38 N/mm <sup>2</sup> , $F_{m, nom}$ : 210 kN		
4	Corrosion protection for temporary rock and soil nails	Cover of cement grout mortar $\geq$ 15mm Attachment 1, Figure 1	-	
5	Corrosion protection, sacrificial corrosion allowance for permanent rock and soil nails	-	Sacrificial corrosion Attachment 1, Figure 1, Attachment 1, Table 1	-
6	Corrosion protection, sacrificial corrosion allowance for hot-dip galvanised permanent rock and soil nails	-		Sacrificial corrosion Attachment 1, Figure 1, Attachment 1, Table 2
7	Impact energy and torque	$E_S$ : 70 Joule, $M_t$ : 440 Nm to $E_S$ : 110 Joule, $M_t$ : 320 Nm		
<b>Hollow bar of welded steel tube</b>				
8	Shape	Attachment 1, Figure 2		
9	Dimensions	Diameter External: 31.1 mm, Internal: 21.0 mm		
10	Surface geometry	Rope thread, pitch 12.7 mm, average thread height 1.6 mm, $f_R$ : 0.13		
11	Mass per metre	2.65 kg/m, deviation: - 4.5 % to + 12 %		
12	Cross sectional area	340 mm <sup>2</sup>		
13	Strength characteristics	$F_{p0.2, nom}$ : 160 kN, $F_{m, nom}$ : 210 kN, $F_m/F_{p0.2}$ : $\geq$ 1.15		
14	Elongation at maximum force	$A_{gt} \geq$ 5 %		
15	Modulus of elasticity	205 000 N/mm <sup>2</sup>		
16	Weld at flattening	No cracking at close flattening prior to rolling		
17	Weld at drift expansion	No cracking at relative expansion $\geq$ 110 % with 60 ° mandrel prior to rolling		
18	Resistance to fatigue	$F_{p0.2, nom}$ : 160 kN, $2\sigma_a$ : 190 N/mm <sup>2</sup> , 2 000 000 cycles		
19	Bond strength	$\tau_{ak}$ : 5.1 N/mm <sup>2</sup> , $f_{cm}$ : 55 N/mm <sup>2</sup>		
20	Hot-dip galvanising	-	-	$\geq$ 85 $\mu$ m

The performance of the product identified above is in conformity with the set of declared performance/s.

Signed for and on behalf of the manufacturer by:

Signed by:  
  
 8B67F3C8A00D446...

Dipl.-Ing. Dominik Johannes Dendl

Pasching, on 08.04.2026

## Declaration of Performance

No. HBS-2026-001 R32-210 Attachment 1

Figure 1: Coupler, Nut

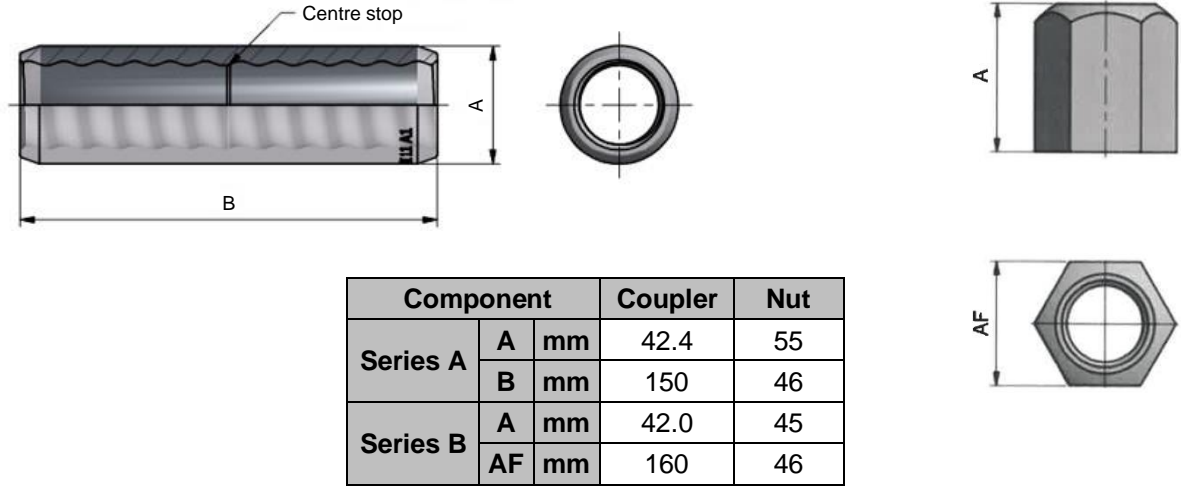

Table 1: Bare steel

Time in years	Corrosion load		
	Low	Medium	High
	Sacrificial corrosion depth in mm		
2	0	0	0.2
7	0.2	0.2	0.5
30	0.3	0.6	-
50	0.5	1.0	-

Table 2: Galvanised steel

Time in years	Corrosion load		
	Low	Medium	High
	Sacrificial corrosion depth in mm		
2	0	0	0.1
7	0	0.1	0.4
30	0.1	0.4	-
50	0.3	0.7	-

Figure 2: Hollow bar

