

RD927L

Hydraulic rock drill

Key features

Hole diameter range	89 – 140* mm (above 127 mm consult factory)
Kinetic power	27 kW
Percussion rate	56 Hz
Percussion pressure	Up to 190 bar
Rotation pressure	Up to 200 bar (depending rotation motor)
Rotation motor types	OMT315 / 400 / 500
Weight	340 kg

Sandvik RD927L is a hydraulic top hammer rock drill designed for tophammer rigs. It is capable of drilling Ø89 - 140 mm holes up to 36 meters in depth. Optimal hole range is from 89 to 115mm, using T51 MF - rods and GT60 mm rods.

The RD927L is a heavy-duty hydraulic rock drill designed for large diameter longhole drilling. The construction of the rock drill is based on three body modules tied together with short side bolts; this ensures minimum number of joint faces and large contact surfaces. The percussion module is simple and reliable in design and consists of only two moving parts – the piston and the distributor sleeve around the piston – all guided by single pilot cylinder, ensuring optimal alignment for parts. The RD927L is fitted with a drill stabilizer, which is designed to keep the shank adapter in optimal position in relation to the piston; this ensures good rock/bit contact and energy transfer, high penetration rate and rock tool service life.

There are three rotation motor variants to meet the rotation torque and RPM requirements in the RD927L application range. Power extractor (option) can be used for opening rock tool joints manually or automatically when using one-hole automation. The design of the RD927L is covered by several patents.

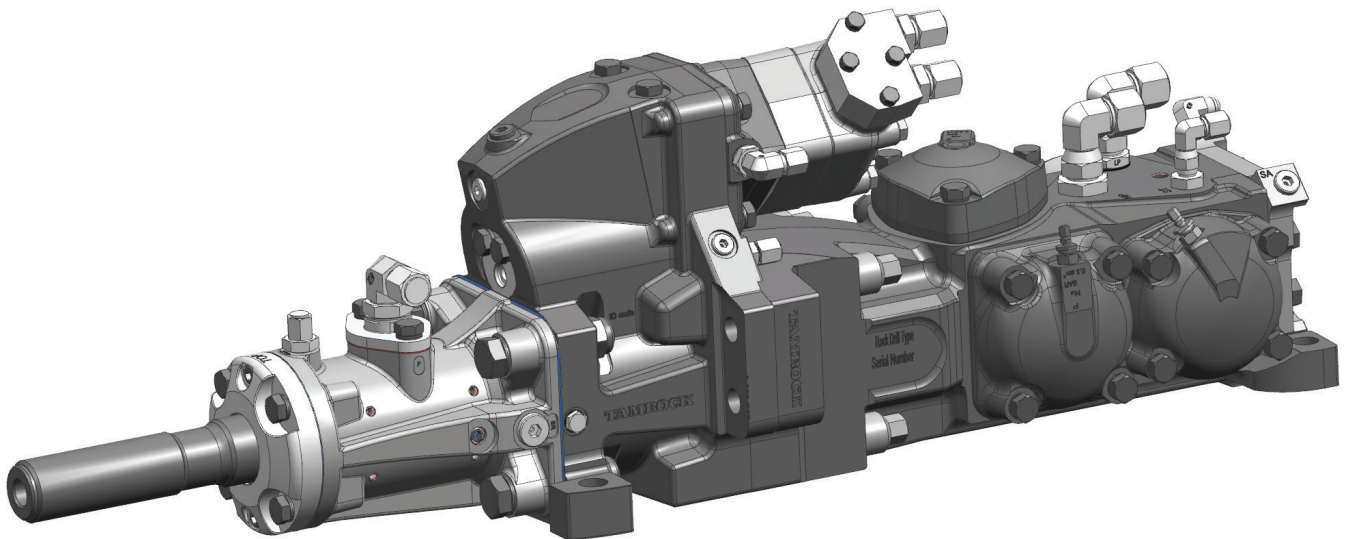

Shank lubrication

	Circulating Shank Lubrication (CSL) **	Oil Mist Lubrication (SLU)
Air flow	0.5 m ³ /min	0.5 m ³ /min
Air pressure	4 bar	4 bar
Oil consumption	~1 lpm*	~800 g/h*
Max. oil pressure	20 bar	
Oil type example	Shell Omala 32/100	Shell air tool oil 32/100

* Depends strongly on drilling parameters
 ** only for surface drill

Accumulators

Accumulator gas	Nitrogen N2
High pressure (HP)	50 bar (2 pcs)
Low pressure (LP)	4 bar (2 pcs)
Stabilizer	40 bar
Filling valve	Vg8 DIN7756

Rotation motors

Motor	OMT 315	OMT 400	OMT 500
Pressure max. (dp)	200 bar	150 bar	120 bar
Flow (at max speed)	125 l/min	125 l/min	125 l/min
Torque at bit	1750 Nm	1750 Nm	1750 Nm
Bit rotation speed max.	190 rpm	150 rpm	120 rpm

Oil recommendation

Oil operating temperature	Between 40°C and 60°C
Oil recommendation	See Sandvik drill lubricant recommendation

Shank types

With rods T51, GT60 bearing Ø52 mm and Ø65 mm

Option

Power extractor	See separate specification
Special tools for RD927L	Field kit or complete set

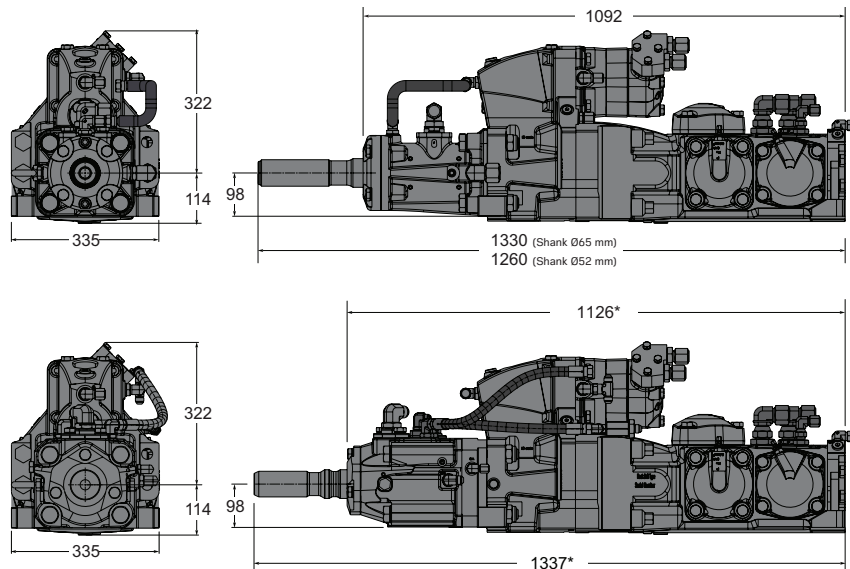

* (With power extractor Ø65 mm length. With power extractor Ø52 mm is the same as with flushing head models)

All dimensions in mm

Sandvik Mining reserves the right to make changes to the information on this data sheet without prior notification to users. Please contact a Sandvik representative for clarification on specifications and options.

TS2-380:01/ENG/METRIC © Sandvik Mining 2024 SANDVIK is a registered trademark owned by Sandvik Intellectual Property AB in Sweden and other countries.