

RD525

Hydraulic rock drill

Key features

Hole diameter drilling	43 - 64 mm
Hole diameter reaming	76 - 127 mm
Power class	25 kW
Percussion rate	93 Hz
Operating pressure percussion	100 - 235 bar
Rotation motor type	OMS 80, OMS 125 or OMS 160
Drill steels	R39 or Hex 35 mm drifter rods, MF-rods highly recommended
Shanks	T35 (male) T38 (male) T45 (male)
Weight	225 kg

Sandvik RD525 hydraulic rock drill is designed for face drilling on Sandvik mine development and tunneling jumbos. It is also suitable for bolt hole, exploration and injection hole drilling.

Sandvik RD525 is a hydraulic percussive rock drill with independent reversible rotation and low profile height. It is known of its hydraulic efficiency and high penetration rate. Sandvik RD525 has excellent serviceability through modular construction and visual wear indicators.

Robustness is achieved by having only few pressurized seams between functional modules. The rock drill is equipped with stabilizer to control contact between drill bit and rock. The stabilizer also dampens recoil impulses from rock and lengthens the lifetime of drilling tools.

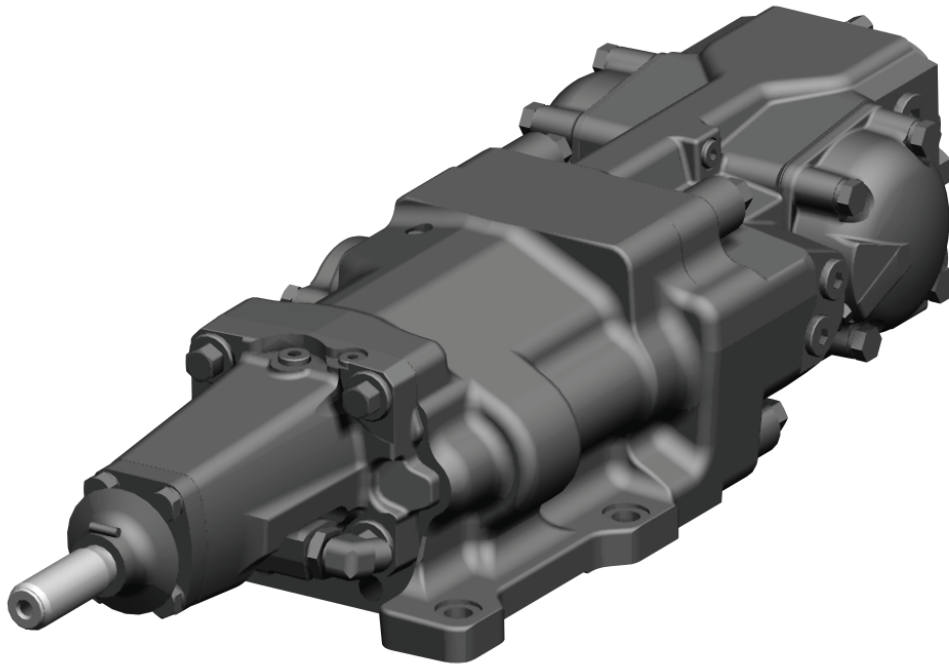

Technical drawing

All dimensions in mm

Rotation mechanism

Motor type	OMS 80	OMS 125	OMS 160
Torque (at 175 bar)	400 Nm	625 Nm	700 Nm
Rotation speed	0 - 400 rpm	0 - 280 rpm	0 - 225 rpm
Flow (at max speed)	65 l/min	75 l/min	75 l/min

Shank lubrication

Air flow	250 - 350 l/min
Pressure	4 - 7 bar
Oil consumption	180 - 250 g/h

Flushing pressure

Max. pressure (air / water)	20 bar
-----------------------------	--------

Oil recommendation

Oil operating temperature	+40°C up to +60°C
Oil recommendation	See Sandvik drill rigs lubricant recommendation for detailed information

Accumulators

Accumulator gas	Nitrogen N2
High pressure (HP)	50 bar
Low pressure (LP)	4 bar
Stabilizer	30 bar
Filling valve	Vg8 DIN7756

Option

Special tools for RD525	ID 551 617 36
Complete set	
Power extractor	See separate specification

Recommended shanks and drill steels

Rock tool	Application	Thread	Length	Shank bearing (mm)	Shank adapter, Sandvik-code
Shank adapter	UG	T35	525	45	7307-7669-01
	UG	T35	600	45	7307-7666-01
	UG	T38	525	45	7304-7669-01
	UG	T45	600	45	7305-7666-01
	UG (for PE)	T35	745	45	7307-7673-01

Drill steels R39 or Hex 35 mm drifter rods, MF-rods highly recommended

