

# RD520

## Hydraulic rock drill

### Key features

Hole diameter drilling	43 - 64 mm
Hole diameter reaming	76 - 127 mm
Power class	20 kW
Percussion rate	74 Hz
Operating pressure percussion	100 - 220 bar
Rotation motor size	80cc, 100cc, 125cc, 160cc
Drill steels	R39 or Hex35 mm drifter rods, MF-rods highly recommended
Shanks	T35 (male) T38 (male) T45 (male)
Weight	225 kg

Sandvik RD520 hydraulic rock drill is designed for face drilling on Sandvik mine development and tunneling jumbos. It is also suitable for bolt hole, exploration and injection hole drilling.

Sandvik RD520 is a hydraulic percussive rock drill with independent reversible rotation and low profile height. It is known of its hydraulic efficiency and high penetration rate. RD520 has excellent serviceability through modular construction and visual wear indicators.

Robustness is achieved by having only few pressurized seams between functional modules. The rock drill is equipped with stabilizer to control contact between drill bit and rock. The stabilizer also dampens recoil impulses from rock and lengthens the lifetime of drilling tools.

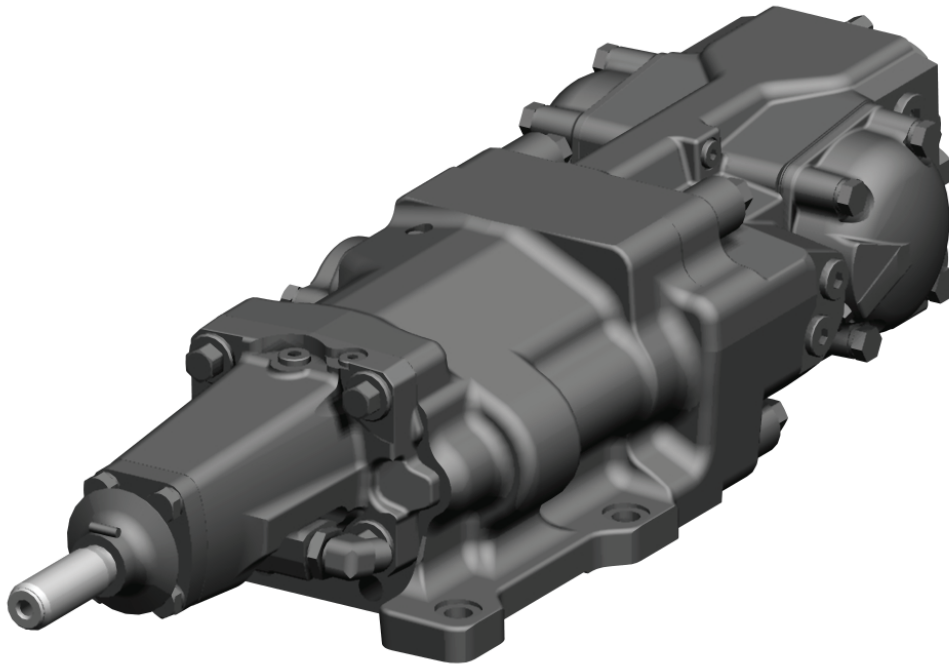

## Technical drawing

All dimensions in mm

### Rotation mechanism

Motor size	80cc	100cc	125cc	160cc
Torque (at 175 bar)	400 Nm	520 Nm	625 Nm	700 Nm
Rotation speed (max)	400 rpm	340 rpm	280 rpm	225 rpm
Flow (at max speed)	65 l/min	75 l/min	75 l/min	75 l/min

### Shank lubrication

Air flow	250 - 350 l/min
Pressure	4 - 7 bar
Oil consumption	180 - 250 g/h

### Flushing pressure

Max. pressure (air / water)	20 bar
-----------------------------	--------

### Oil recommendation

Oil operating temperature	+40°C up to +60°C
Oil recommendation	See Sandvik drill rigs lubricant recommendation for detailed information

### Accumulators

Accumulator gas	Nitrogen N2
High pressure (HP)	50 bar
Low pressure (LP)	4 bar
Stabilizer	30 bar
Filling valve	Vg8 DIN7756

### Options

Special tools for RD520/525	See specification TS2-438
Complete set	
Special tools for RD520/525	See specification TS2-440
Field tool set	
Power extractor	See separate specification

### Recommended shanks and drill steels

Rock tool	Application	Thread	Length	Shank bearing (mm)	Shank adapter, Sandvik-code
Shank adapter	UG	T35	525	45	7307-7669-01
	UG	T35	600	45	7307-7666-01
	UG	T38	525	45	7304-7669-01
	UG	T45	600	45	7305-7666-01
	UG (for PE)	T35	745	45	7307-7673-01

Drill steels R39 or Hex 35 mm drifter rods, MF-rods highly recommended

