

HL820T

Hydraulic rock drill

Key features

Hole diameter	64 - 127 mm
Power class	21 kW
Percussion rate	53 Hz
Operating pressure	200 bar 80 – 200 bar (percussion) 200 bar (rotation max.)
Rotation motor type	OMT 200, OMT 250, OMT 315
Drill steels	38 mm / 45 mm / 51 mm
Shank adapter	Male type, side flushing
38 mm rods (Not optimal)	T38 / 600
45 mm rods	T45 / 600
51 mm rods (Optimal)	T51 / 600

Sandvik HL820T hydraulic rock drill is designed for drilling 64 - 127 mm diameter holes in Sandvik hydraulically controlled surface long hole drill rigs.

Sandvik HL820T is a heavy hydraulic percussive rock drill with independent rotation and separate flushing. High drilling capacity and reliability are enabled by functional modules. Sandvik HL820T is equipped with a hydraulic stabilizer to control contact between drill bit and rock. This ensures optimal drilling performance with high drill steel life time. Three rotation motor options are available for torque/speed adjustment.

Optional Power Extractor guarantees trouble-free drilling in extreme conditions. The design is covered by several patents.

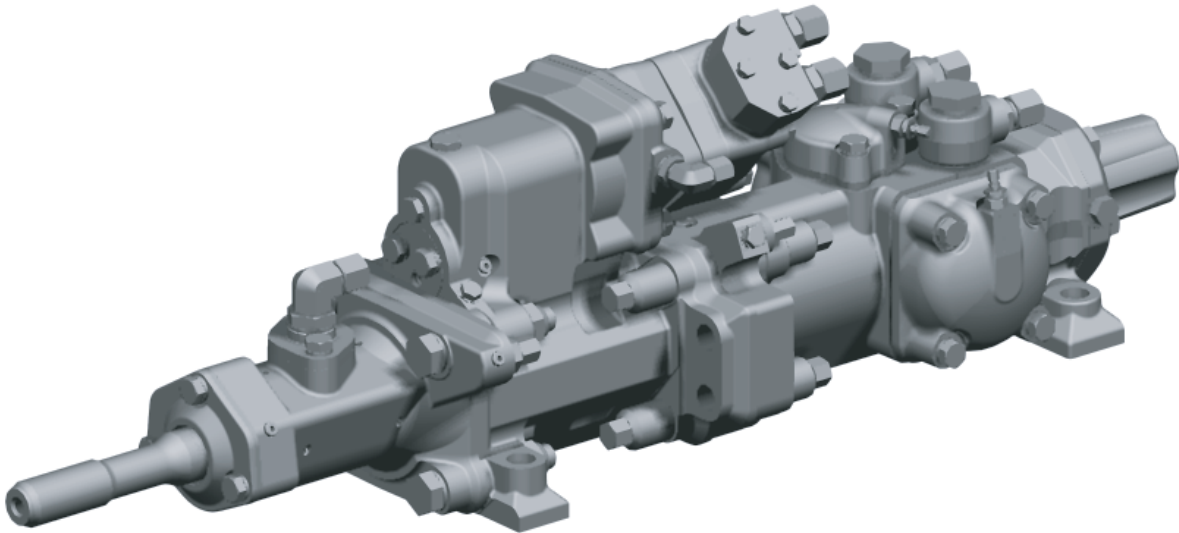

Technical drawing

All dimensions in mm

Rotation mechanism

Motor	Orbit type (3 options)		
Motor type	OMT200	OMT250	OMT315
Torque (200 bar)	1095 Nm	1335 Nm	1765 Nm
Rotation speed	0 - 180 rpm	0 - 180 rpm	0 - 180 rpm
Flow (at max.speed)	79 l/min	99 l/min	128 l/min

Flushing

Max. pressure (air / water)	20 bar
-----------------------------	--------

Shank lubrication

Air flow (pressurized)	200 - 300 l/min
Air pressure (at rock drill)	4 - 7 bar
Oil consumption	400 - 850 g/h

Oil recommendation

Oil operating temperature	+40°C - +60°C
Oil recommendation	See Sandvik drill rigs lubricant recommendation for detailed information

Main dimensions

Overall length	1342 mm
Length	1140 mm
Profile height	291 mm
Width	334 mm
Weight	265 - 310 kg

Accumulators

Accumulator gas	Nitrogen N2
High pressure (HP)	50 bar
Low pressure (LP)	4 bar
Stabilizer	30 bar
Filling valve	Vg8 DIN7756

Options

Special tools for HL820T Complete tool set	Specification TS2-452
Special tools for HL820T Field tool set	Specification TS2-453
Power extractor	See separate specification

