

HL820ST

Hydraulic rock drill

Key features

Hole diameter range	54 - 89 mm
Kinetic power	21 kW
Percussion rate	42 - 53 Hz
Percussion pressure	80 - 200 bar
Rotation pressure	Up to 200 bar
Rotation motor range	OMT200 / 250
Stabilizer	Sleeve type
Shank length	600 mm

Rock tools and hole diameters

Thread	Rod Ø (mm)	Hole Ø (mm)
T35	39	54 - 57
T38	39	64
T45	46	76
T45	65 (tube)	76 - 89
T51	52	89

Sandvik HL820ST is a hydraulic top hammer rock drill designed for DL311 and DL321 underground longhole drills. It is capable of drilling Ø54 - 89 mm holes up to 38 meters in depth, using T35, T38, T45, T51 MF-rods or Ø65 mm tube rods.

Sandvik HL820ST hydraulic rock drill is designed to ensure high drilling capacity, easy maintenance and low operating cost. The construction of the rock drill is based on the main body modules tied together with four short side bolts; this ensures minimum number of joint faces and large contact surfaces. The percussion module is simple in design and consists of only two moving parts – the piston and the distributor sleeve around the piston. The moving parts are not in contact with the rock drill body modules.

The HL820ST is fitted with a drill stabilizer, which is designed to adjust percussion power according to variations in rock conditions. This ensures good rock/bit contact and energy transfer, high penetration rate and rock tool service life.

There are two rotation motor variants to meet the rotation torque and RPM requirements of different hole diameters and rock formations. The optional power extractor is used for opening rock tool joints manually or automatically when using one-hole or fan automation. The design of the HL820ST is covered by several patents.

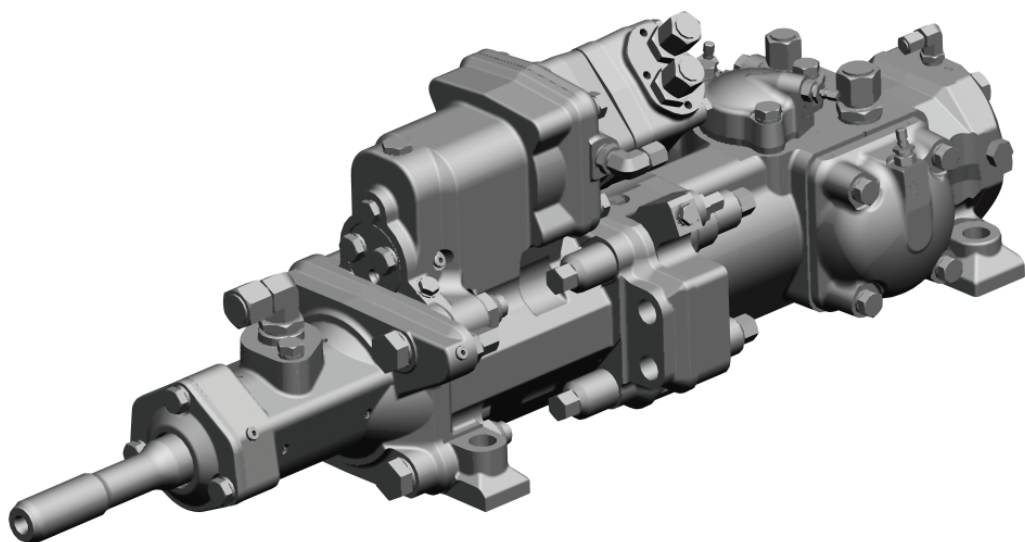

Technical drawing

All dimensions in mm

Rotation mechanism

Motor	Orbit type	
Motor type	OMT200	OMT250
Torque (200 bar)	1095 Nm	1335 Nm
Rotation speed	0 - 180 rpm	0 - 180 rpm
Flow (at max.speed)	79 l/min	99 l/min

Flushing

Max. pressure (air / water)	20 bar
-----------------------------	--------

Shank lubrication

Air flow (pressurized)	200 - 300 l/min
Air pressure (at rock drill)	4 - 7 bar
Oil consumption	400 - 850 g/h

Oil recommendations

Oil operating temperature	+40°C - +60°C
Oil recommendation	See Sandvik drill lubricant recommendation for detailed information

Main dimensions

Overall length	1241 mm
Length	1039 mm
Profile height	282 mm
Width	334 mm
Weight	260 - 305 kg

Accumulators

Accumulator gas	Nitrogen N2
High pressure (HP)	50 bar
Low pressure (LP)	4 bar
Stabilizer	30 bar
Filling valve	Vg8 DIN7756

Options

Special tools for HL820ST Complete tool set	Specification TS2-452
Special tools for HL820ST Field tool set	Specification TS2-453
Power extractor	See separate specification

