

HL710

Hydraulic rock drill Surface drill

Key features

Hole diameter drilling	64 - 115 mm
Power class	19.5 kW
Percussion rate	42 - 52 Hz
Operating pressure percussion Rotation (max.)	100 - 190 bar 200 bar
Rotation motor type	OMT 200, OMT 250 or OMT 315
Drill steels	38 mm 45 mm 51 mm
Shanks	
38 mm rods	T38 / 600
45 mm rods	T45 / 600
51 mm rods	T51 / 600
Weight	245 kg

Sandvik HL710 hydraulic rock drill is designed for long hole drilling of 64 - 115 mm diameter holes. It is used in Sandvik underground production and surface drill rigs.

Sandvik HL710 is a heavy hydraulic percussive rock drill with independent rotation and separate flushing. High drilling capacity and reliability is achieved through functional modules.

Three rotation motor type options are available for torque/speed adjustment. The design is covered by several patents.

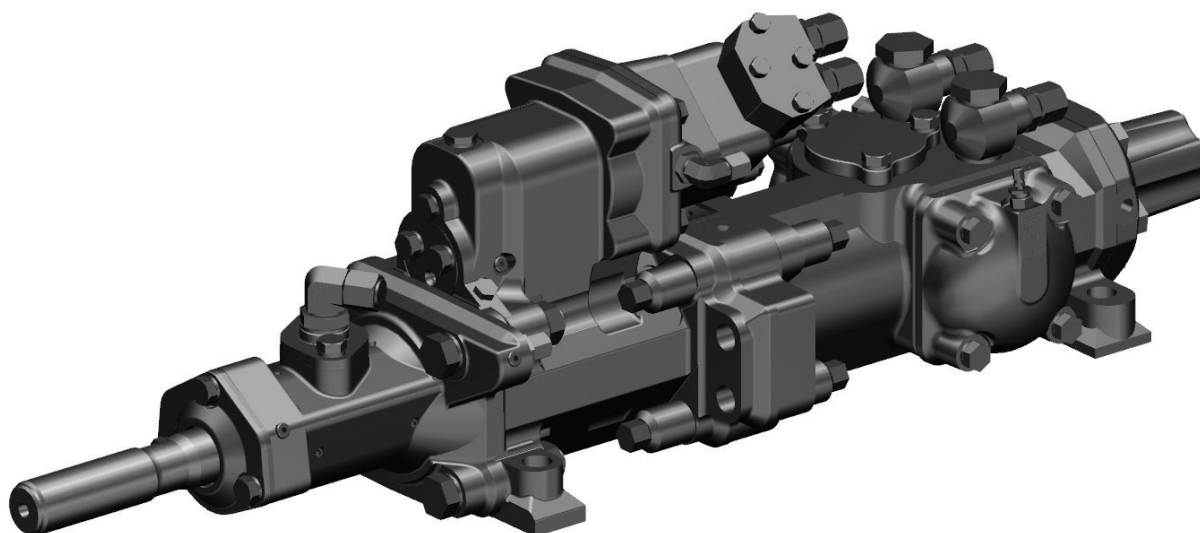

Technical drawing

All dimensions in mm

Rotation mechanism

Motor	Orbit type
Motor type 1	OMT 200
Torque (at 175 bar)	1095 Nm
Rotation speed	0 - 180 rpm
Flow (at max speed)	79 l/min

Rotation mechanism

Motor	Orbit type
Motor type 2	OMT 250
Torque (at 175 bar)	1335 Nm
Rotation speed	0 - 180 rpm
Flow (at max speed)	99 l/min

Rotation mechanism

Motor	Orbit type
Motor type 3	OMT 315
Torque (at 175 bar)	1765 Nm
Rotation speed	0 - 180 rpm
Flow (at max speed)	128 l/min

Flushing pressure

Max. pressure (air / water)	20 bar
-----------------------------	--------

Accumulators

Accumulator gas	Nitrogen N2
High pressure (HP)	50 bar
Low pressure (LP)	4 bar
Filling valve	Vg8 DIN7756

Shank lubrication

Air flow	200 - 300 l/min
Pressure	4 - 7 bar
Oil consumption	400 - 850 g/h

Oil recommendation

Oil operating temperature	+40°C up to +60°C
Oil recommendation	See Sandvik drill rigs lubricant recommendation for detailed information

Option

Special tools for HL710 Complete set	Specification TS2-449
Special tools for HL710 Field tools set	Specification TS2-450
Power extractor	See separate specification

