

# HL1560ST

## Hydraulic rock drill

### Technical data

Hole diameter range	89 - 127 mm
Kinetic power	33 kW
Percussion rate	30 - 40 Hz
Percussion pressure	90 - 200 bar
Rotation pressure	Up to 200 bar
Rotation motor types	OMT 400, OMT 500
Stabilizer	Sleeve type
Weight	470 - 490 kg

### Rock tools and hole diameters

Thread	Rod Ø (mm)	Hole Ø (mm)
T51	52	89
ST58	76 (tube)	89 - 102
ST68	87 (tube)	102 - 127

Sandvik HL1560ST is a hydraulic top hammer rock drill designed for DL411 and DL421 underground longhole drills. It is capable of drilling Ø89 - 127 mm holes up to 54 meters in depth, using T51 MF - rods or ST58 and ST68 tube rods.

Sandvik HL1560ST is a heavy-duty hydraulic rock drill designed for large diameter longhole drilling. The construction of the rock drill is based on three body modules tied together with short side bolts; this ensures minimum number of joint faces and large contact surfaces. The percussion module is simple in design and consists of only two moving parts – the piston and the distributor sleeve around the piston - which are not in contact with the body of the rock drill.

Sandvik HL1560ST is fitted with a stabilizer, which is designed to keep the shank adapter in optimal position in relation to the piston; this ensures good rock/bit contact and energy transfer, high penetration rate, good hole straightness and rock tool service life.

There are two rotation motor variants to meet the rotation torque and RPM requirements in the HL1560ST application range. Power extractor (option) can be used for opening rock tool joints manually or automatically when using one-hole or fan automation. The design of Sandvik HL1560ST is covered by several patents.

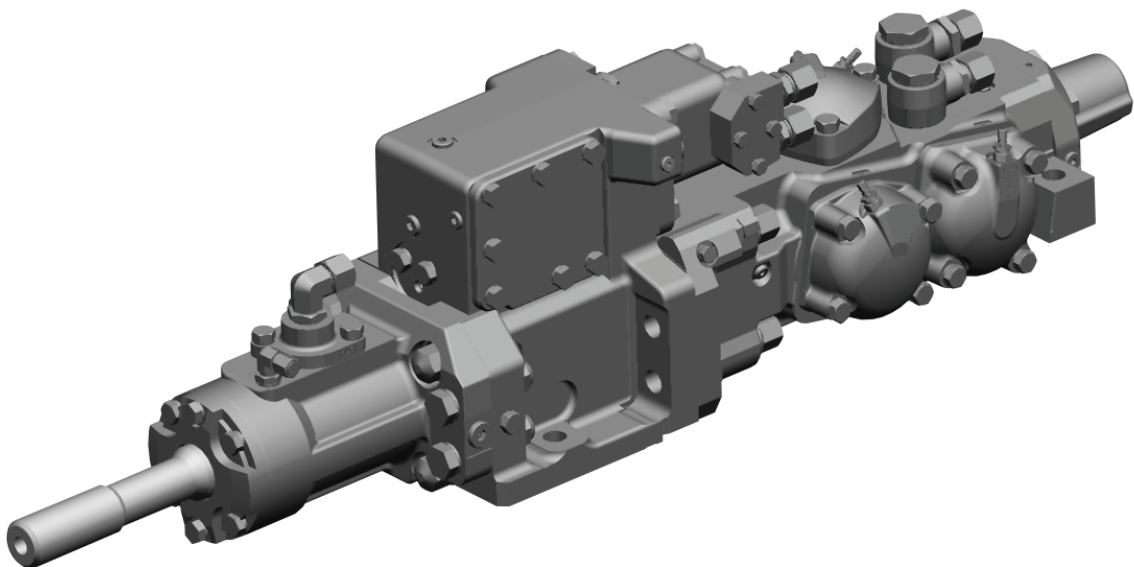

## Technical drawing

All dimensions in mm

### Rotation motors

Motor	Orbit type	Orbit type
Motor type	OMT 400	OMT 500
Max. rotation torque	2005 Nm (180 bar)	2330 Nm (170 bar)
Rotation speed	0 - 100 rpm	0 - 100 rpm
Flow (at max speed)	85 l/min	113 l/min

### Flushing pressure

Max. pressure (air / water)	20 bar
-----------------------------	--------

### Shank lubrication

Air flow (at 6 bar)	300 - 400 l/min
Pressure	4 - 7 bar
Oil consumption	600 - 1200 g/h

### Actuator for shank control (stabilizer)

Operating principle	Hydraulically controlled, for holding the shank adapter in optimal position in relation to the piston
Operating pressure	60 - 110 bar (adjustable)

### Accumulators

Accumulator gas	Nitrogen N2
High pressure (HP)	50 bar (2 pcs)
Low pressure (LP)	4 bar (2 pcs)
Stabilizer	40 bar
Filling valve	Vg8 DIN7756

### Oil recommendation

Oil operating temperature	Between 40°C and 60°C
Oil recommendation	See Sandvik drill lubricant recommendation

### Options

Power extractor	Specification 2-2010
Special tools for HL1560T	Field kit (ID 55038795) Complete set (ID 55042018)

