

HF820T

Hydraulic rock drill

Key features

| | |
|--------------------------|--|
| Hole diameter | 64 - 127 mm |
| Power class | 23 kW |
| Percussion rate | 60 Hz |
| Operating pressure | 230 bar 100 – 230 bar (percussion) 200 bar (rotation max.) |
| Rotation motor type | OMT 200, OMT 250, OMT 315 |
| Drill steels | 38 / 45 / 51 mm |
| Shank adapter | Male type, side flushing |
| 38 mm rods (Not optimal) | T38 / 600 |
| 45 mm rods | T45 / 600 |
| 51 mm rods (Optimal) | 51 / 600 |

Sandvik HF820T hydraulic rock drill is designed for drilling 64 - 127 mm diameter holes. This rock drill belongs to Sandvik hydraulically controlled surface and underground long hole drill rigs.

Sandvik HF820T is a heavy hydraulic percussive rock drill with independent rotation and separate flushing. High drilling capacity and reliability are enabled by functional modules. Sandvik HF820T is equipped with a hydraulic stabilizer to control contact between drill bit and rock. This ensures optimal drilling performance with high drill steel life time. Three rotation motor options are available for torque/speed adjustment.

Optional power extractor guarantees trouble-free drilling in extreme conditions. The design is covered by several patents.

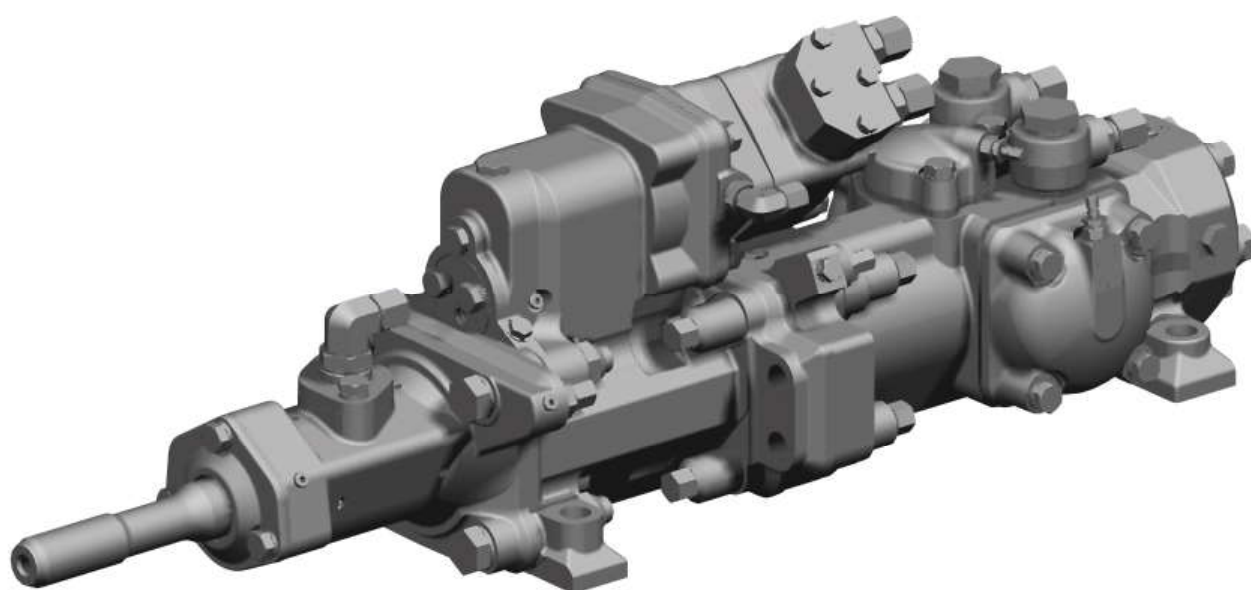

Rotation mechanism

| | | | |
|----------------------|------------------------|-------------|-------------|
| Motor | Orbit type (3 options) | | |
| Motor type | OMT200 | OMT250 | OMT315 |
| Torque (200 bar) | 1095 Nm | 1335 Nm | 1765 Nm |
| Rotation speed | 0 - 180 rpm | 0 - 180 rpm | 0 - 180 rpm |
| Flow (at max. speed) | 79 l/min | 99 l/min | 128 l/min |

Main dimensions

| | |
|----------------|--------------|
| Overall length | 1268 mm |
| Length | 1066 mm |
| Profile height | 291 mm |
| Width | 334 mm |
| Weight | 265 - 310 kg |

Shank lubrication

| | |
|------------------------------|-----------------|
| Air flow (pressurized) | 200 - 300 l/min |
| Air pressure (at rock drill) | 4 - 7 bar |
| Oil consumption | 400 - 850 g/h |

Oil recommendation

| | |
|---------------------------|--|
| Oil operating temperature | +40°C up to +60°C |
| Oil recommendation | See Sandvik drill rigs lubricant recommendation for detailed information |

Accumulators

| | |
|--------------------|--------------|
| Accumulator gas | Nitrogen N2 |
| High pressure (HP) | 50 bar |
| Low pressure (LP) | 4 bar |
| Stabilizer | 30 bar |
| Filling valve | Vg8 DIN 7756 |

Options

| | |
|--|----------------------------|
| Special tools for HF820T Complete set | Specification TS2-452 |
| Special tools for HF820T Field service set | Specification TS2-453 |
| Power extractor | See separate specification |

Flushing pressure

| | |
|-----------------------------|--------|
| Max. pressure (air / water) | 20 bar |
|-----------------------------|--------|

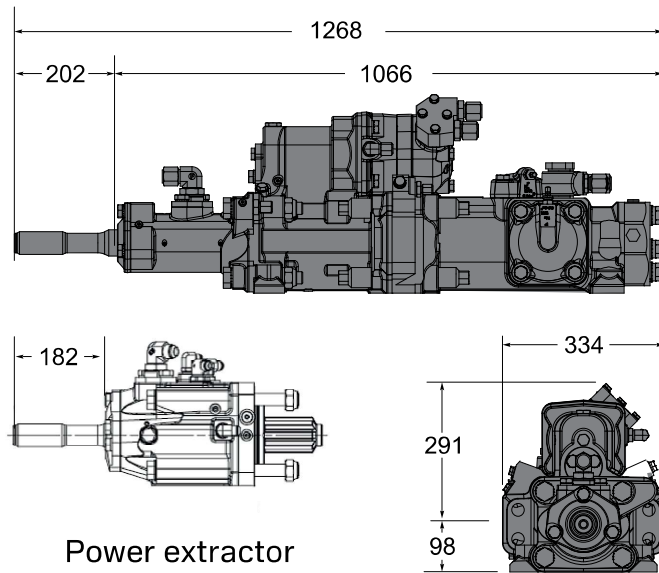

Power extractor

All dimensions in mm

Sandvik Mining reserves the right to make changes to the information on this data sheet without prior notification to users. Please contact a Sandvik representative for clarification on specifications and options.

TS2-213:04/ENG/METRIC © Sandvik Mining 2024 SANDVIK is a registered trademark owned by Sandvik Intellectual Property AB in Sweden and other countries.